

## MODELO N° 300BR:

Forged Steel Class 800 CHECK VALVE

Lift Type,

Bolted Cap, Optional: Weld Cap.

Manufacture and Design:

API 602/ ANSI B16.34 FULL PORT/STANDARD PORT

Connection: Threaded Ends , Socket Ends Thread Type (NPT, BSPT, DIN ENDS),

Inspection and Test: API 598.

Pressure Rating: SHELL: 3000PSI

SEAT: 2200PSI

AIR TEST: 80-100PSI

MATERIAL: A 105, A 182 F304/ F316/ F11/ F22/ F304L/ F316L

SIZE: 1/4"-2"



### • PARTS AND MATERIAL:

N°	PARTS NAME	MATERIALS		
1	BODY	ASTM A105	A182 F304	A182 F316
2	DISC	F6	A182 F316	A182F316
3	GASKET	GRAPHITE+304GRAPHITE +316		
4	CAP	ASTM A105	A182 F304	A182 F316
5	CAP BOLT	ASTM A193 B7	ASTM A193 B8	
OTHER MATERIALS ARE AVAILABLE UPON REQUEST				

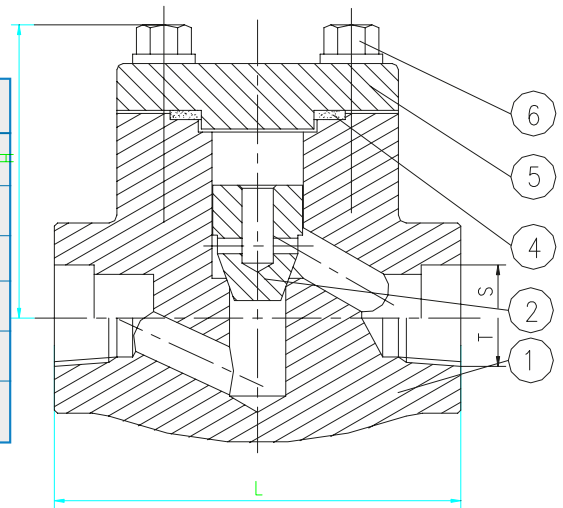

### • DIMENSIONS LIST:

UNIT: MM

DN		SIZE		T (THREAD)S		(SOCKET)		L	H	WT(KG)
REGULAR	FULL	REGULAR	FULL	REGULAR	FULL	REGULAR	FULL			
8		1/4"		1/4"		14.2		79	61	1.5
10	8	3/8"	1/4"	3/8"	1/4"	17.6	14.2	79	61	1.4
15	10	1/2"	3/8"	1/2"	3/8"	21.8	17.6	79	61	1.2
20	15	3/4"	1/2"	3/4"	1/2"	27.1	21.8	92	61	1.4
25	20	1"	3/4"	1"	3/4"	33.8	27.1	111	78	2.3
32	25	1-1/4"	1"	1-1/4"	1"	42.6	33.8	120	84	3.9
40	32	1-1/2"	1-1/4"	1-1/2"	1-1/4"	48.7	42.6	152	103	5.6
50	40	2"	1-1/2"	2"	1-1/2"	61.1	48.7	172	118	8.9
	50		2"		2"		61.1	200	132	12.5