

Forged Steel Gate Valves, Threaded & Socket-welding End, CLASS 800 (PN 130)

Class 800 (PN 130)
Full Port/Standard Port
ASME CLASS 800: 1975 psi@100°F
(136.2 bar@38°C)

Features

- API 602 / ASME B16.34
- Spiral wound gasket with SS304 / graphite or SS316 / graphite
- Solid wedge
- Outside screw & yoke (OS&Y)
- Two-piece self-aligning gland
- Compact and sturdy designs for high pressure-temperature service
- Replacement of handwheel without affecting the gate position

Forged steel
gate valve



3



1219 Antoine Drive, Houston, TX 77055

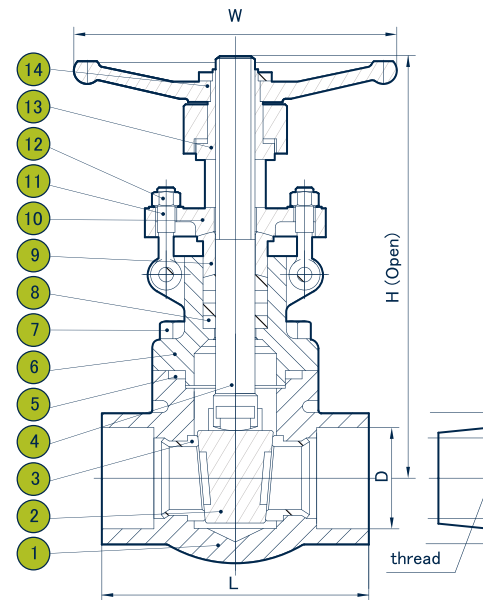

Component and Common Materials				
NO.	PARTS NAME	MATERIALS		
1	Body	A 105	A 182-F304	A 182-F316
2	Wedge	13Cr	A 182-F304	A 182-F316+STL
3	Seat Ring	13Cr	A 182-F304+STL	A 182-F316+STL
4	Stem	A 276-410	A 182-F304+STL	A 182-F316
5	Gasket	SS304 & Graphite		SS316 & Graphite
6	Bonnet	A 105	A 182-F304	A 182-F316
7	Bonnet Bolt	A 193-B7		A 193-B8
8	Stem Packing	Reinforced Graphite		
9	Gland	A 276-410	A 182-F304	A 182-F316
10	Gland Flange	A 216-WCB	A 105	A 182-F304
11	Gland Eyebolt	A 193-B7		A193-B8
12	Gland Nut	A 194-2H		A 193-B8
13	Stem Nut	A 108-1020		A 276-410
14	Handwheel	A 197		

* Enclosed is a condensed table. For complete options, contact DIE ERSTE directly.

Selection

Connection:
Threaded End/Socket-welding End
Thread Type:
NPT/BSPT/DIN
OS&Y Type:
Bolted Bonnet/Welded Bonnet
Material of the Body/Bonnet:
A105/F316/F316L/F304/F304L/F11/F22

Nominal diameter	Standard Port	mm(in)	8(1/4)	10(3/8)	15(1/2)	20(3/4)	25(1)	32(1 1/4)	40(1 1/2)	50(2)	
	Full port	mm(in)	-	-	10(3/8)	15(1/2)	20(3/4)	25(1)	32(1 1/4)	40(1 1/2)	50(2)
D	mm(in)	7(0.28)	7(0.28)	10(0.39)	12.7(0.5)	18(0.71)	23(0.91)	28.5(1.12)	36(1.41)	43(1.69)	
L	mm(in)	79(3.11)	79(3.11)	79(3.11)	92(3.62)	111(4.37)	120(4.72)	120(4.72)	140(5.51)	170(6.69)	
H (Open)	mm(in)	166(6.54)	166(6.54)	166(6.54)	169(6.65)	193(7.64)	230(9.06)	246(9.69)	283(11.14)	332(13.07)	
W	mm(in)	100(3.94)	100(3.94)	100(3.94)	100(3.94)	125(4.92)	160(6.30)	160(6.30)	180(7.09)	200(7.87)	
Weight	B.B	kg	2.5	2.4	2.3	2.5	4.5	5.9	7.2	11.2	18.8
	W.B	kg	-	-	2.4	2.7	4.6	6.1	7.4	11.4	19.1

Forged Steel Gate Valves, Threaded & Socket-welding End, CLASS 1500 (PN 260)

Class 1500 (PN 260)
Full Port
ASME CLASS 1500: 3705 psi@100°F
(255.5 bar@38°C)



Gate Valve

4



Selection

Connection:
Threaded End/Socket-welding End
Thread Type:
NPT/BSPT/DIN
OS&Y Type:
Bolted Bonnet/Welded Bonnet
Material of the Body/Bonnet:
A105/F316/F316L/F304/F304L/F11/F22

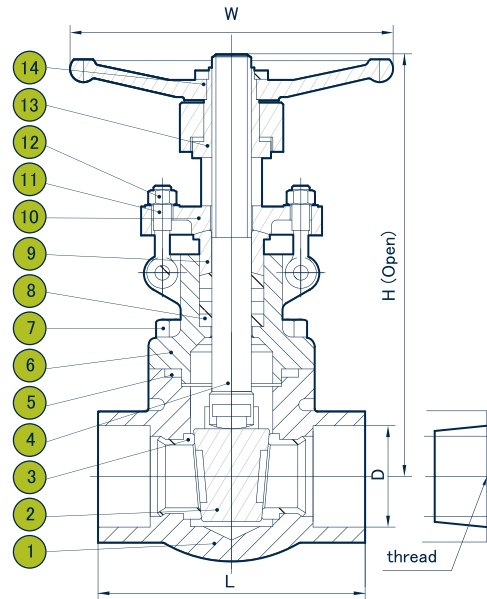

Nominal diameter	mm(in)	10(3/8)	15(1/2)	20(3/4)	25(1)	32(1 1/4)	40(1 1/2)	50(2)	
D	mm(in)	10(0.39)	12.7(0.5)	18(0.7)	23(0.91)	28.5(1.12)	36(1.41)	43(1.69)	
L	mm(in)	111(4.37)	111(4.37)	111(4.37)	120(4.72)	120(4.72)	140(5.51)	170(5.51)	
H (Open)	mm(in)	170(6.69)	193(7.60)	230(9.06)	246(9.69)	283(11.14)	325(12.79)	334(13.15)	
W	mm(in)	125(4.92)	125(4.92)	160(6.30)	160(6.30)	180(7.09)	200(7.87)	200(7.87)	
Weight	B.B	kg	4.7	4.7	6.8	9	12.4	17.5	18.0
	W.B	kg	4.8	4.8	6.9	9.2	12.6	17.7	17.9



Features

- API 602 / ASME B16.34
- Spiral wound gasket with SS304 / graphite or SS316 / graphite
- Solid wedge
- Outside screw & yoke (OS&Y)
- Two-piece self-aligning gland
- Compact and sturdy designs for high pressure-temperature service
- Replacement of handwheel without affecting the gate position

Component and Common Materials				
NO.	PARTS NAME	MATERIALS		
1	Body	A 105	A 182-F304	A 182-F316
2	Wedge	13Cr	A 182-F304+STL	A 182-F316+STL
3	Seat Ring	13Cr	A 182-F304+STL	A 182-F316+STL
4	Stem	A 276-410	A 182-F304	A 182-F316
5	Gasket	SS304 & Graphite		SS316 & Graphite
6	Bonnet	A 105	A 182-F304	A 182-F316
7	Bonnet Bolt	A 193-B7		A 193-B8
8	Stem Packing	Reinforced Graphite		
9	Gland	A 276-410	A 182-F304	A 182-F316
10	Gland Flange	A 216-WCB	A 105	A 182-F304
11	Gland Eyebolt	A 193-B7		A193-B8
12	Gland Nut	A 194-2H		A 193-B8
13	Stem Nut	A 108-1020		A 276-410
14	Handwheel	A 197		

* Enclosed is a condensed table. For complete options, contact DIE ERSTE directly.