

CHEECK VALVE CLASS 150/300/600

DESIGN DESCRIPTION:

- Bolted Cover
- Swing Type
- For Horizontal Or Vertical Lines
- Renewable Seat Rings
- Flanged Ends
- Buttwelding Ends.

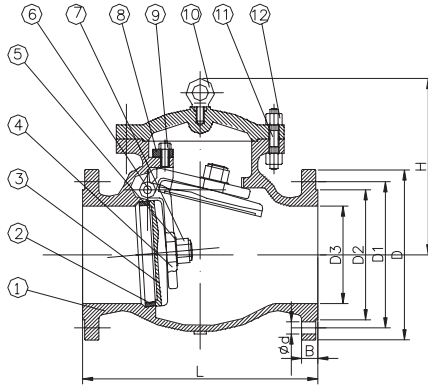

TEST PRESSURE TO API 598

APPLICABLE STANDARDS :

- Manufacture: API 6D.
- Basic Desing: ANSI B16.34
- Face To Face: ANSI B16.10
- End Flange: ANSI B16.5
- Buttwelding Ends: ANSI B16.25
- Inspection And Test: API 6D OR API 598

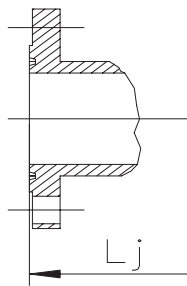

RING TYPE JOINT END

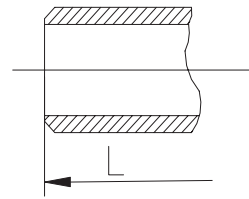

BUTT WELDING END

PARTS AND MATERIAL (ASTM)

N°	PARTS NAME	MATERIALS		
		WCB	WC6	LCB
1	BODY	A216-WCB	A217-WC6	A352-LCB
2	SEAT	A105+H/F STL#6	A217-WC6+H/F STL#6	A350-LF2+H/F STL#6
3	DISC	A216-WCB+H/F 410	A217-WC6+H/F 410	A352-LCB+H/F 410
4	SWING ARM	A216-WCB	A217-WC6	A325-LCB
5	DISC WASHER	A182	A182	A182
6	SWING ARM PIN	A276-410	A276-410	A276-410
7	DISC NUT	A194-8	A194-8	A194-8
8	BACK BOARD NUT	A216	A216	A216
9	BACK BOARD PLUG	A194-8	A194-8	A194-8
10	EYE BLOT	A307 B	A307 B	A307 B
11	COVER BLOT	A193-B7	A193-B7	A193-B7M
12	GLAND FLANGE	A194-2H	A194-2H	A194-2HM

OTHER MATERIALS ARE AVAILABLE UPON REQUEST

CLASS	SHELL TEST (WATER)		SEAT TEST (WATER)		SEAT TEST (AIR)	
150	3.1 MPA	450PSIG2	2.2 MPA	315PSIG	0.6MPA	80PSIG
300	7.8 MPA	1125PSIG	5.6 MPA	815PSIG	0.6MPA	80PSIG
600	15.3 MPA	2225PSIG	11.2 MPA	1630PSIG	0.6MPA	80PSIG

DIMENSIONS AND WEIGHT TABLE

• CLASS 150 CHECK VALVE FLANGE END AND WELDING END

DN	NPS	d	L	LJ	D	D1	D2	B	Z-d	H	Wt(kg)
50	2	2	8	8 -1/2	6	4-3/4	3-5/8	5/8	4-3/4	6-1/4	17
65	2 -1/2	2 -1/2	8-1/2	9	7	5-1/2	4-1/8	11-16	4-3/4	6-5/8	25
80	3	3	9- 1/2	10	7 -1/2	6	5	3/4	4-3/4	7-1/8	29
100	4	4	11- 1/2	12	9	7-1/2	6-3/16	15/16	8-3/4	8	50
150	6	6	14	14 -1/2	11	9-1/2	8 -1/2	1	8-7/8	10-7/8	85
200	8	8	19-1/2	20	13 -1/2	11 -3/4	10-5/8	1-1/8	8-7/8	13	150
250	10	10	24-1/2	25	16	14-1/4	12-3/4	1-3/16	12-1	15	240
300	12	12	27 -1/2	28	19	17	15	1-1/4	12-1	16-1/8	350
350	14	14	31	31 -1/2	21	18-3/4	16-1/4	1-3/8	12-1-1/8	20-5/8	460
400	16	16	34	34 - 12	23-1/2	21-1/4	18-1/2	1-7/16	16-1-1/8	22-1/2	495

• CLASS 300 FLANGE END AND WELDING END

50	2	2	10-1/2	11-1/8	6-1/2	5	3-5/8	7/8	8-3/4	6-7/8	28
65	2-1/2	2-1/2	11-1/2	12-1/8	7-1/2	5-7/8	4-1/8	1	8-7/8	7-1/8	33
80	3	3	12-1/2	13-1/8	8-1/4	6-5/8	5	1-1/8	8-7/8	7-1/2	45
100	4	4	14	14-5/8	10	7-7/8	6-3/16	1-1/4	8-7/8	9-1/2	70
150	6	6	17-1/2	18-1/8	12-1/2	10-5/8	8-1/2	1-7/16	12-7/8	12	150
200	8	8	21	21-5/8	15	13	10-5/8	1-5/8	12-1	14-1/4	230
250	10	10	24-1/2	25-1/8	17-1/2	15-1/4	12-3/4	1-7/8	16-1-1/8	16-1/4	390
300	12	12	28	28-5/8	20-1/2	17-3/4	15	2	16-1-1/4	17-3/4	520
350	14	14	33	33-5/8	23	20-1/4	16-1/4	2-1/8	20-1-1/4	21-5/8	710

• CLASS 600 FLANGE END AND WELDING END

50	2	2	11-1/2	11-5/8	6-1/2	5	3-5/8	1	8-3/4	8	32
65	2-1/2	2-1/2	13	13-1/8	7-1/2	5-7/8	4-1/8	1-1/8	8-7/8	8-5/8	42
80	3	3	14	14-1/8	8-1/4	6-5/8	5	1-1/4	8-7/8	9-3/8	60
100	4	4	17	17-1/8	10-3/4	8-1/2	6-3/16	1-1/2	8-1	11	110
150	6	6	22	22-1/8	14	11-1/2	8-1/2	1-7/8	12-1-1/8	15	220
200	8	8	26	26-1/8	16-1/2	13-3/4	10-5/8	2-3/16	12-1-1/4	17-1/4	390
250	10	10	31	31-1/8	20	17	12-3/4	2-1/2	16-1-3/8	20-3/4	630
300	12	12	33	33-1/8	22	19-1/4	15	2-5/8	20-1-3/8	25-1/4	870